

IONIZER USER MANUAL

Model 6100/6200

Static Ion Bar & Air Knife



IONIZER U S E R M A N U A L

Model 6100/6200

Static Ion Bar & Air Knife

Contents

1. Core Insight Introduction	4
2. Ionization Technology	5
A. Steady State DC Ionization	
B. AC Ionization	
C. Bipolar Pulsed AC Ionization	
D. High Frequency AC Ionization	
E. Pulsed DC Ionization	
3. Application Guide	7
A. Basic ESD Control	
B. Ionization for CDM/CBE Controls	
4. Cautions and Personal Safety	8
A. Cautions	
B. Personal Safety	
5. General Specification	9
6. Drawings	10
7. Setup and Operation	10
A. Introduction	
B. Contents in the box	
C. Descriptions for Model 3890E	
D. Installation	
E. Turning on the ionizer	
F. Alarm	
8. Maintenance	15
9. Warranty and Services	16

Core Insight Introduction 1

Core Insight, Inc. is an ionization system manufacturer and supplier to ESD and contamination control application. Core Insight, Inc. also provides ESD Test and Measurement equipment, Professional Static Auditing Kits, EMI Noise Filters and EOS/ESD Technical Services such as ESD Training, Process Assessment, ESD Control Program Development and Product Qualification Testing per ANSI/ESD Standards.

Core Insight, Inc. is a leading company for ESD and contamination control in the fields of semiconductors, flat panel displays, automotive, and general electronic manufacturing industries. Core Insight, Inc. was founded in 2003 and business partnership with ProStat Corporation, ON Filter, Monroe Electronics, Electro-Tech Systems, and Dangelmayer Associates etc.

2 Ionization Technology

A. Ionization Theory

Ionization solution has been used many years in electronic industry. Electrical ionization technology is most common design for many applications. Some ionizers designed for ESD application and some of them are contamination control in high technology manufacturing environment. Both are different purpose and may not work in both applications. Follows are the brief summary of differences and user guide for each applications.

B. Cleanroom Contamination Application

Electric field is one of strong force to attract particles on wafer, glass panel, printed circuit board and other insulator materials. To minimize this force, room ionization is the best solution in high technology and other cleanroom environment.

Pulsed DC ionization technology is the well known solution over many years to minimized air borne particle attraction in cleanroom environment. Using with laminar flow, generated ions can move long distance and wide coverage areas. This will significantly reduce the force between particles and sensitive devices such as wafer, flat panel display and medical items. In results, room ionization improves product yields and less losses.

C. ESD Control Application

Voltage (or Potential) difference is the reason why ESD event occurs and lead to device damage. Ionizer makes this voltage difference to the same or minimize the level between objects to avoid ESD damage or make it happen at the safe level.

Steady-State DC ionizer is provide high ion current to objects and maintain low peak (or offset) voltage on it. This makes minimize ESD risk in production and suitable for CDM ESD control in control program.

2 Ionization Technology

CoreStat® Self-Balanced Ionizers developed based on steady-state DC technology and upgraded the ground isolated power circuit design. It can maintain low peak (or offset) voltage performance by intrinsic balancing circuit design with longer maintenance cycle time. It does not require calibration or adjust to maintain low offset voltage and it needs to cleaning emitter points for decay performance.

D. AC Ionizations and Application

Core Insight, Inc. provides several AC ionization systems. Conventional AC ionizer for industrial applications such as roll to roll or winding & unwinding of paper, film and non-ESD sensitive areas. Bipolar Pulsed AC ionizer is output parameter adjustable technology to meet each application requirements. High Frequency AC has adopt piezo crystal power supply for neutralize charge on insulative materials in small package. AC ionizer generates more Ozone than DC in the environment and may cause of side effects in sensitive device handling areas.

All ionizers performed and tested per ANSI/ESD STM3.1 and other documents such as ANSI/ESD SP3.3, ANSI/ESD SP3.4 and ANSI/ESD SP3.5.

For more detail information about ionizer solution and technical support needed, please feel free to contact our sales representative at sales@coreinsight.co.kr or your local contacts.

3 Application Guide

A. Basic ESD Control

Basic ESD control is mandatory required to electronic industry. It follows simple principle to make equipotential between ESD sensitive items. Personal grounding, ESD safe worksurfaces and ESD safe packaging materials are the key control items in ESD protected area.

B. Ionization for CDM/CBE Controls

Due to automated process in high technology manufacturing environment, Charged Device Model (CDM) or CDM-like ESD damage becoming a major portion of device failures. Industry Council agreed to reduction of CDM protection target level down to 125V level and will impact basic level of ESD control program and organization. Not only CDM, but also Charge Board Event (CBE) like ESD issues are increasing due to device complexity and stored large amount of charge on printed circuit board.

Strategic guidance has been proposed by the EOS/ESD Association. Lowering device charged voltage level and increasing resistance of contact materials are the key strategic elements to prevent or minimize ESD damage.

ANSI/ESD S20.20 standard requires maximum allowable field strength is 125 V/inch for 200 V CDM device. Low peak (or offset) voltage of ionizer performance is important for ESD sensitive device control and control program per S20.20 based.

Core Insight, Inc. provides intrinsic low peak balancing Steady-State DC Ionizers for CDM ESD control with less maintenance.

For more detail information about ionizer solution and technical support needed, please feel free to contact our sales representative at sales@coreinsight.co.kr or your local contacts.

Cautions and Personal Safety 4

A. Cautions

Use of proper input voltage to avoid damaging the system.

Verify the cabling and its connection between controller, junction box and individual ceiling emitters before turn on the system.

Disconnection cable from ceiling emitters will damage the system.

Do not clean emitter point while the system is powered. This may result of additional contamination issue and possible electrical shock.

Do not open the system by un-authorized personnel while the system is powered. This will void the warranty and may result in additional cost.

B. Personal Safety

Before performing any maintenance on emitter points, it is highly recommended turn-off the system. Allow few minutes for high voltage power supplies to discharge.

5 General Specification

Input Voltage	100 ~ 240 VAC, 50/60Hz
Ion Emission	Conventional AC & Pulsed AC Technology
Effectiveness Length	75 ~ 3700 mm
Overall Length	100 ~ 3800 mm
Mounting Distance	20 ~ 300 mm to target
Emitter Point	Stainless Steel 304
Enclosure	Anodized Aluminum
Air Pressure Alarm	105 psig (0.7 MPa Maximum) Maximum Visual & Audio alarm operates power failure with Model 620 Power unit
Operating Environment	Temperature: 15 ~ 35 °C Humidity: 35 ~ 60% RH
Maximum Speed	360 m/min or 6 m/sec
Dimensions(mm)	22.4H x 19D x 100 up to 3000L mm
Weight	90 g
Warranty	1 year limit warranty

Status	Visual	Audio
Normal Operation	Green	Inactivate
HV Power Fail	RED	Continuous Sound

Drawing 6

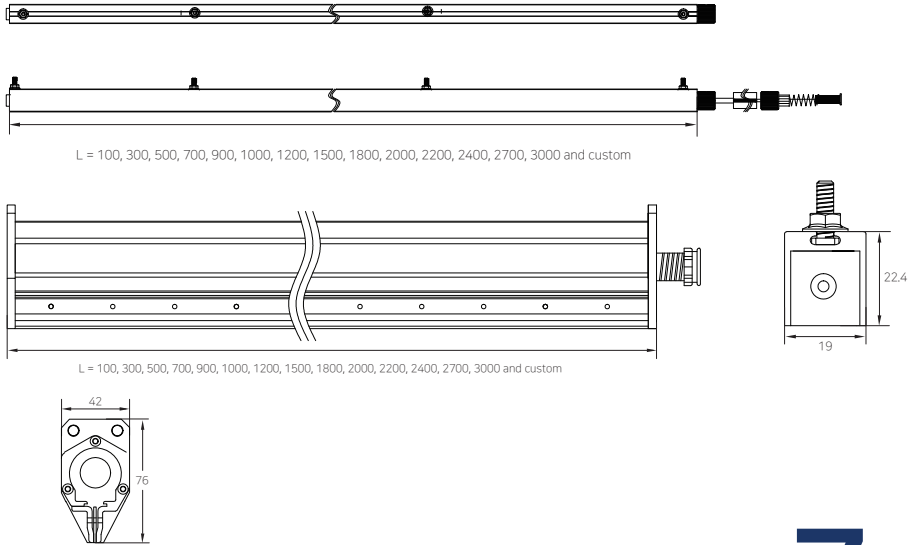

Setup and Operation 7

A. Introduction

Model 6100/6200 Shockless Static Ion Bar is designed to provide neutralization for particle removal applications industrial applications such as roll-to-roll process of paper or films. Conventional AC technology is cost effective solution with Model 610 power unit. Pulsed AC technology with Model 620 allows versatile application solution in static control.

Model 6200 AirKnife Static Ion Bar can remove particles or cooling plastic materials after mold or high temperature processes.

7 Setup and Operation

B. Descriptions



Model 6100 Static Ion Bar



Model 6200 AirKnife Static Ion Bar

7 Setup and Operation

C. Descriptions for Power Units

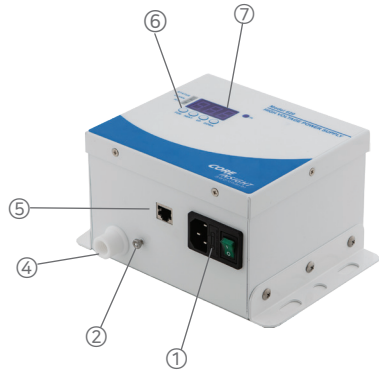

- 1) AC Input Power Connector & Power Switch
- 2) Ground Reference Connect to 6100/6200 Static Ion Bar
- 3) 100/220V AC Switch
- 4) Output Connector to 6100/6200 Static Ion Bar
- 5) Output Monitoring System
- 6) Output Adjustable Switch
- 7) LED Display for Output Parameters

7 Setup and Operation

D. Installation

Determine the location of Model 6100/6200 shockless (air knife) static ion bar using the bracket supplied by Core Insight. Make sure ground cable of Model 6100/6200 shockless (air knife) static ion bar to power units either Model 610 or Model 620. User must be concern air pressure, air blockage or near conductive object between ionizers and neutralizing items.

Warning

Model 610 and Model 620 power unit must plug to properly grounded AC line voltage. If these power units does connect not properly ground AC line source, this may can cause of electrical shock or other problems with ionizers.

E. Turning on the ionizer

Connect Model 6100/6200 to Model 610 or Model 620 power unit. Connect power unit to AC power line and turn on switch. Verify appropriate operation distance and optimize output air pressure by speed controller adjustment.

Model 6200 AirKnife Shockless Stati Ion Bar is 24 hours operating with compressed air. User can additional compressed air output on/off controller if needed. Make sure air pressure is acceptable for application before actual use.

F. Alarm

In an alarm status, the RED LED on top of Model 620 power unit will light on instead of green LED and activate audio alarm too. When ionizer high voltage power unit operates abnormal way, alarm LED operates with continous sound audio alarm.

7 Setup and Operation

8 Maintenance

Warning

There are no user-serviceable parts inside the ionizer. Any unauthorized service will void the warranty and may result in additional repair charge.

General Maintenance Information

Emitter point maintenance ensures continued performance of ionizer. Dirt of erosion to emitter points can be caused by a number of environmental factors, including airborne molecular contamination issue in cleanroom.

Step 1. Recommended Cleaning Materials:

- 1) Cleanroom-compatible cloth or wipe
- 2) Cleanroom approved swabs (foam is not recommended)
- 3) Cleaning solution of 50% isopropyl alcohol (IPA) and 50% deionized water mixture

Caution

Do not clean emitter points while the unit is powered. Doing so may result in additional contamination and possible shock. After removing power from the ionizer, allow few minutes for high voltage power supplies to discharge.

Step 2. Cleaning Inside of Enclosure

Moisten a cloth with the IPA solution. Wipe off any dirt that may have accumulated inside of the unit.

Step 3. Cleaning the Emitter Points

Turn off the unit or just simply unplug ionizer from controller or adapter. Cleaning procedure must be done without electrical power and no high voltage activated. Clean the emitter points and areas around the emitter points, moisten a cleanroom-compatible swab or cleaning cloth with the IPA solution, or use cleaning solution from Core Insight. Gently rotate the swab or cleaning cloth around the emitter point. After cleaning allow the emitter points for dry out about 20 minutes. Turn on the system.

Warranty and Service 9

Core Insight, Inc. provides a limited warranty for all ionizers. New products manufactured or sold by Core Insight, Inc. are guaranteed to be free from defects in material or workmanship for a period of defined schedules from the date of initial shipment. Core Insight, Inc.'s liability under its new product warranty is limited servicing (evaluating, repairing or replacement) any unit returned from customers that has not been subjected to misuse, neglect, lack of routine maintenance, repair, alteration or accident. In no event shall Core Insight, Inc. be liable for collateral or consequential damages.

To obtain service under this warranty, please contact sales representative at sales@coreinsight.co.kr or local contacts.



